



# Assembly Guide

[www.gl-racing.com](http://www.gl-racing.com)

A new benchmark of Low Center Gravity on 1/27 Mini RC – GLR-GT

Ver00

GL Racing and Development Team conducts a wide research and consultation for 1:27-1:28 scale RC car racing and the GLR-GT is developed and test intensively on track by GL Team Drivers and group of experienced RC car players.

Performance is always our goal with no compromise for case of drive, adjustment, maintenance and optional upgrade. All levels of player will be benefited by a proper setup GLR-GT chassis for at least 0.5sec or more faster in average lap-times.

Traction roll is substantially reduced by further lowering down the CG, new suspension design and geometry:

1. “One layered” electronics layout without stacking to achieve the lowest and optimized CG.
2. Micro but most-wanted “Cable Routers” to ensure obstacle-free rear subframe movement.
3. “Roller-Bearing” side shock mechanism for more stroke, sensitivity and centered gravity.
4. New Long Doubled-Wishbone front suspension and geometry for less traction roll.
5. Less traction roll even with lighter springs for more mechanical grip and bumpy track.
6. New optional Front Anti-Roll Bar for fine and most demandable tuning requirement.
7. New Slide Linkage design optimized positioning.
8. Few conversion parts for switching in between 98 to 102mm wheelbase in option.
9. Stock adjustable and optional tuning Front and Rear Tri-Damper.
10. Aluminum Motor Mount for best heat dissipation.
11. Full and high quality ball bearing.
12. Lightened and ultra-smooth rear ball differential.

GL Racing products are designed and developed in Hong Kong. Our high-end and performance product is recommended for player with age of 14 or over.

Thanks for choosing GL Racing.

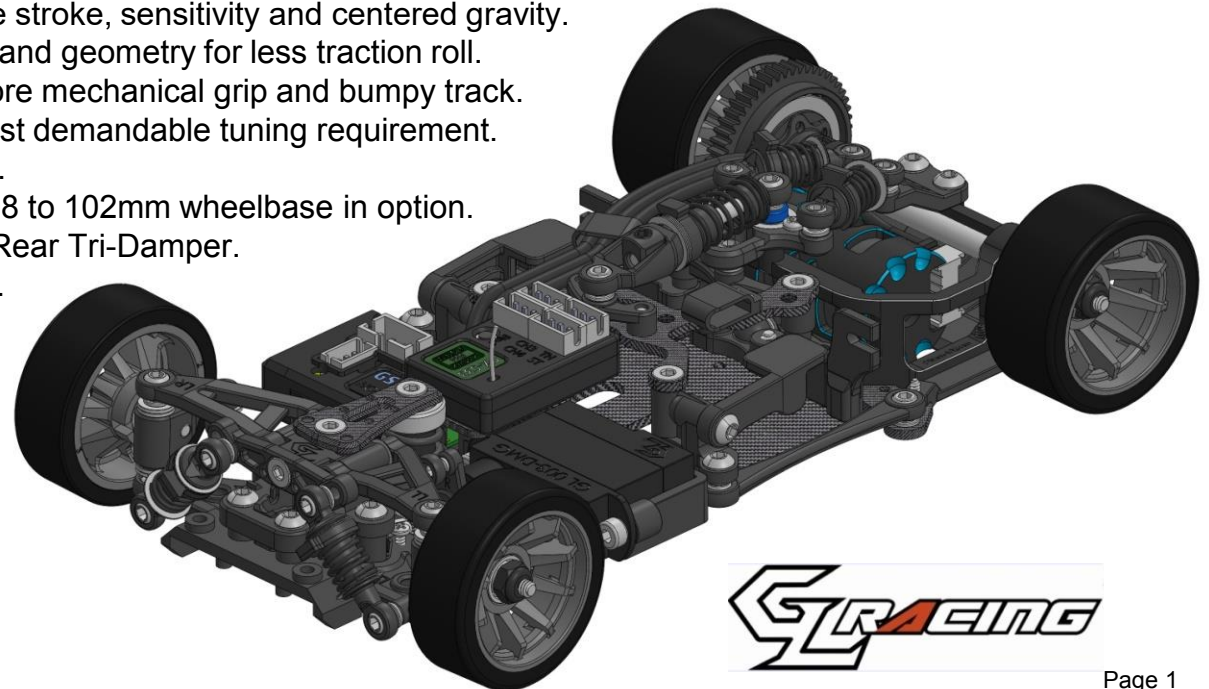

# Bag A (1-5)

## A-1



257014 x1

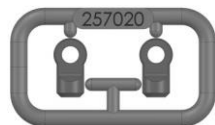

257020 x1

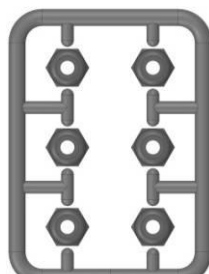

Lock Nut x1

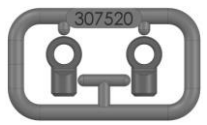

307520 x1

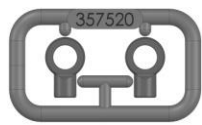

357520 x1

## A-2



G1 x1



G2 x1



G6 x1



G7 x1



G3 x1



G4 x1



G5 x1

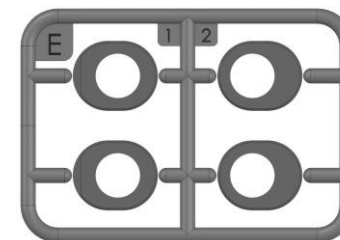

E Pack x1

## A-3

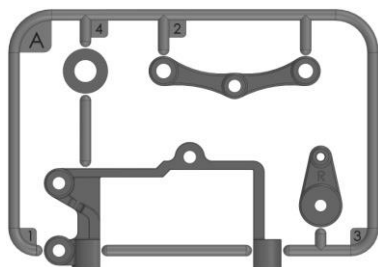

A Pack x1

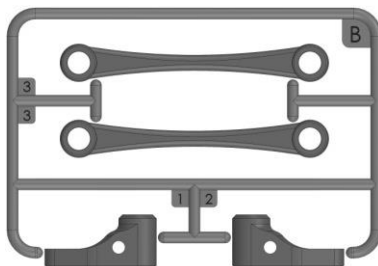

B Pack x1

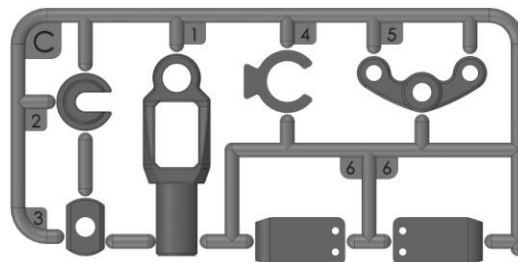

C Pack x1

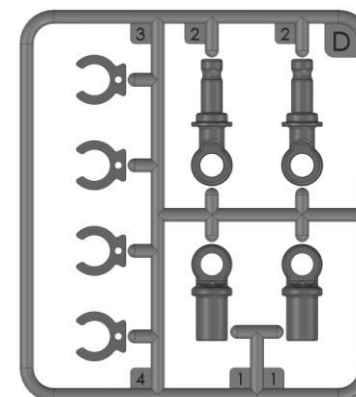

D Pack x2

Bag A (1-5)



A-4



G8 x1



G9 x1

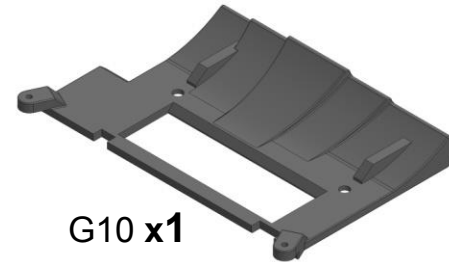

G10 x1

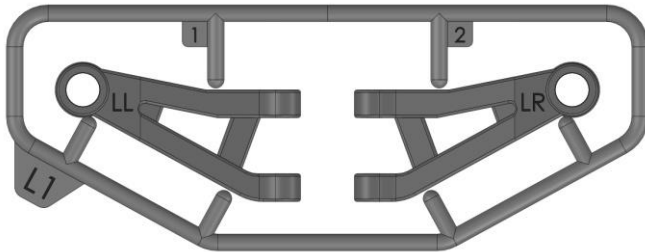

L1 Pack x1

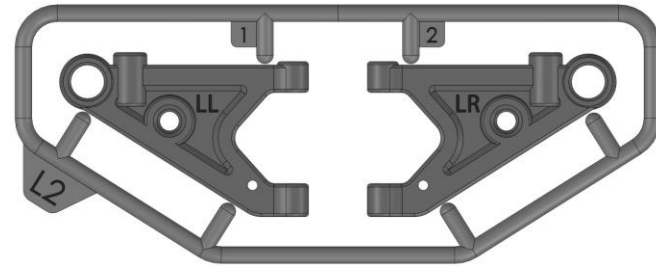

L2 Pack x1

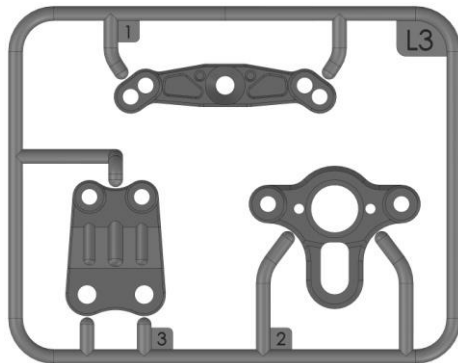

L3 Pack x1

A-5 (Pinion Gear from 9T to 14T)



9T x1



10T x1



11T x1



12T x1



13T x1



14T x1

Bag B

Bag C (1-8)

B-1



G12 x1



G14 x1



G13 x1



G15 x1

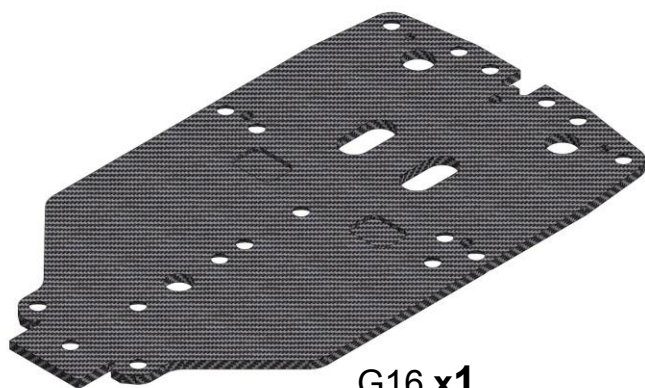

G16 x1

C-1

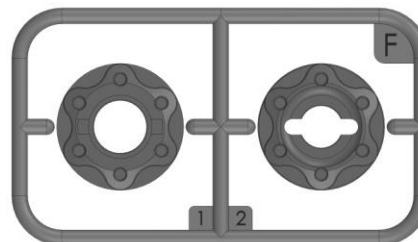

F Pack x1



53T x1



H1 x1



H2 x10  
(Ball 2.381mm)



H3 x1



H4 x1



BE-3625 x1  
(3x6x2.5)mm



H5 x1



M3x3 Grub x1

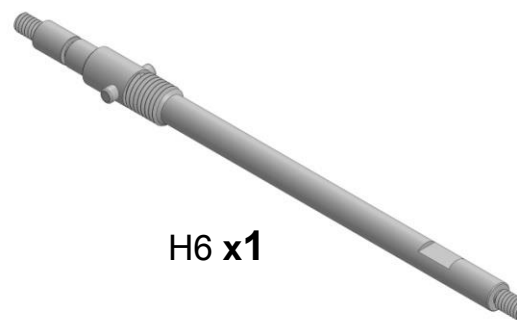

H6 x1



H7 x2

# Bag C (1-8)

## C-2

Hard (0.9)  
(Black)



SP-3 x1

Soft (0.8)  
(Red)



SP-4 x1



G11 x1



G17 x1



G18 x1



G19 x1

## C-3



H8 x2



H9 x2



H10 x1



2x4x1.5 x1



PI-1516 x2  
(1.5x16mm)



PI-15115 x2  
(1.5x11.5mm)



H11 x1  
(Ø1.5x6mm  
Threaded Rod)

## C-4



H12 x4  
(BS-2502)



H13 x12  
(BS-3025)



H16 x1  
(BS-3580)



H14 x4  
(BS-3540)



H15 x5  
(BS-3520)

## C-5

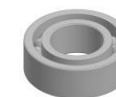

BE-3620 x2  
(3x6x2)mm

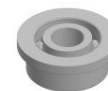



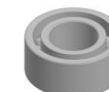

BE-2523 x1  
(2x5x2.3mm with Flanged)





BE-3625 x7  
(3x6x2.5)mm

# Bag C (1-8)















## C-6

-   
**SM1 x10**  
(2x4x0.1)
-   
**SM2 x10**  
(2x4x0.2)
-   
**SM3 x10**  
(2x4x0.3)
-   
**SM4 x5**  
(3x4.5x0.1)
-   
**SM5 x10**  
(2.3x4.4x0.5)
-   
**SM6 x10**  
(4.2x6.4x0.2)
-   
**SM7 x5**  
(5x7x0.2)

## C-7

-   
**1.5 x1**
-   
**1.3 x1**
-   
**0.9 x1**

## C-8

-   
**M1x2.5 PM x5**
-   
**M1.2x2.5 PM x3**
-   
**M1.2x3 PB x3**
-   
**M1.2x4 PB x5**
-   
**M1.5x3.5 PM x3**
-   
**M1.6x4 PM x3**
-   
**M2x3 KM x5**
-   
**M2x4 KM x7**
-   
**M2x3 PM x3**
-   
**M2x4 PM x3**
-   
**M2x4 Cup Head x5**
-   
**M2x4 PB x7**
-   
**M2x4 KB x22**
-   
**M2x6 KB x6**
-   
**M2.5x2 Grub x2**

Bag D

D-1



**GT-S-035 x1**  
(GL003 DMG)



**SP-1 x4**  
(Ø5.3x6.5)mm



**SP-2 x1**  
(Ø6x11)mm



**GT-S-036 x1**



**G20 x1**

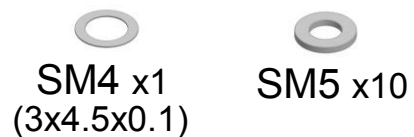
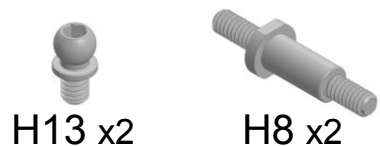
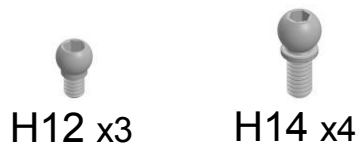

**\*\*Front Ride High Adjustment\*\***

Down ←————→ UP

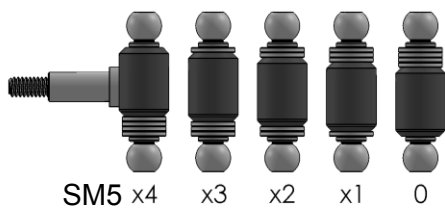

Switching the spacer SM5 to top for the adjustment

**Options: Alloy Steering Hub**

- GT-OP-008-0
- GT-OP-008-1
- GT-OP-008-2
- GT-OP-008-3

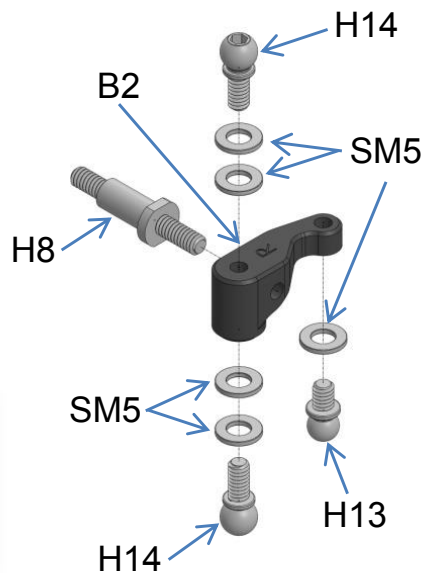

**Options: Alloy Steering Hub**

- GT-OP-008-0
- GT-OP-008-1
- GT-OP-008-2
- GT-OP-008-3

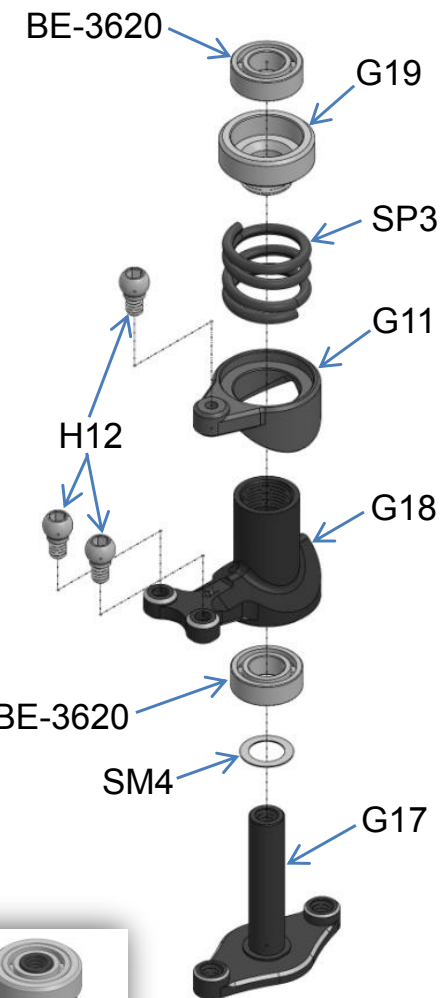
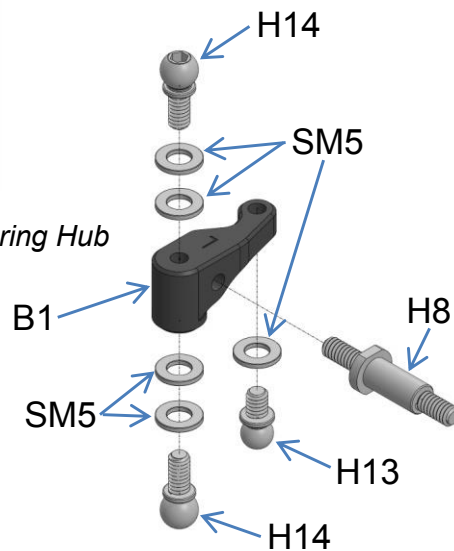







**M1.2x3 PB x2**  
 Down Stop Screw



**M2x4 PB x4**

**H13 x2**

**PI-1516 x2**  
 (M1.5x16)

**PI-15115 x2**  
 (M1.5x11.5)

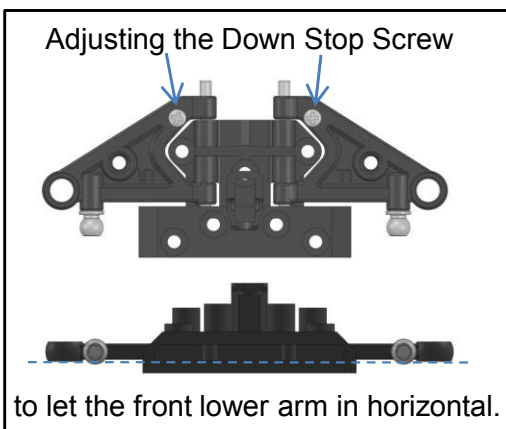
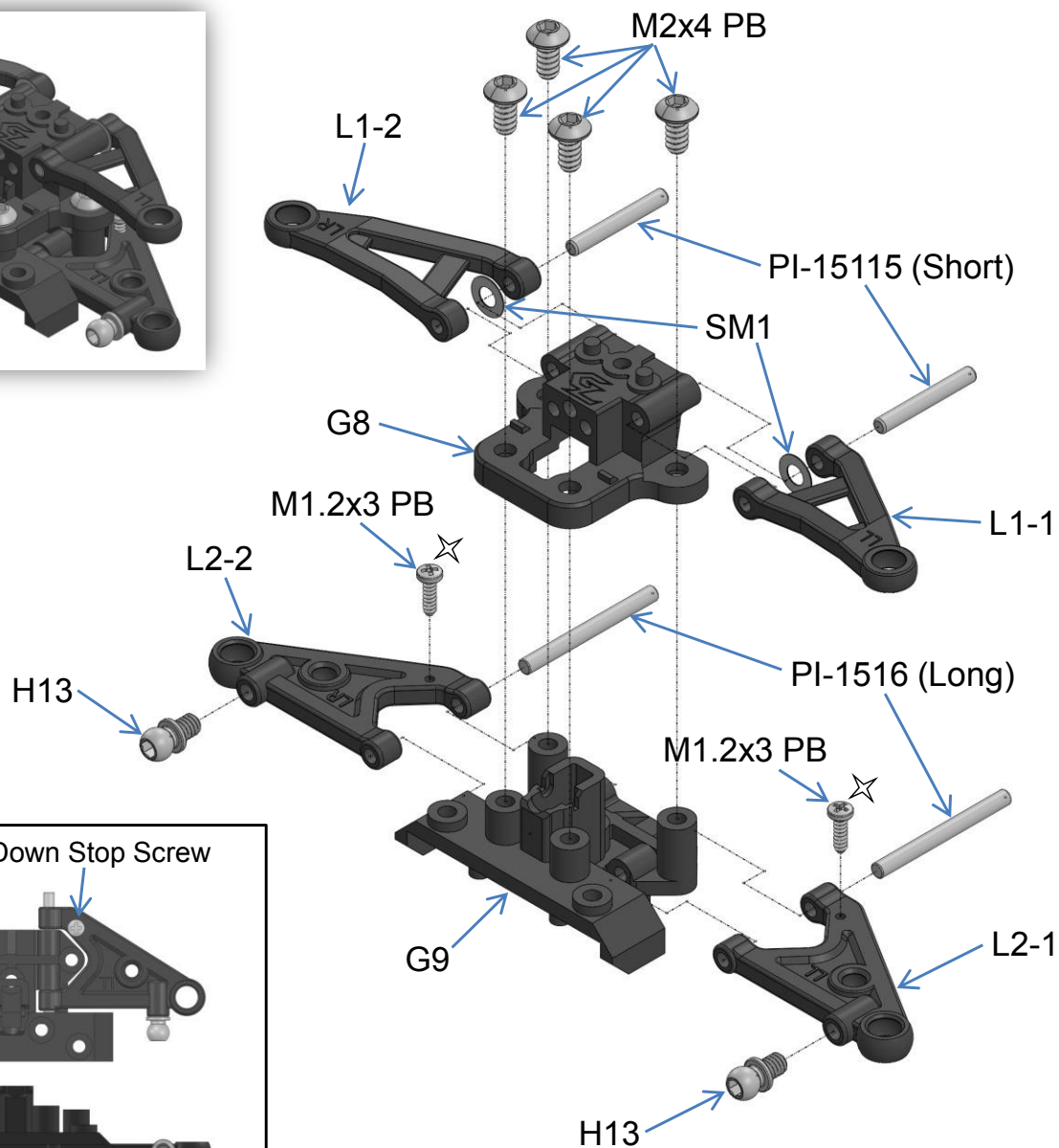
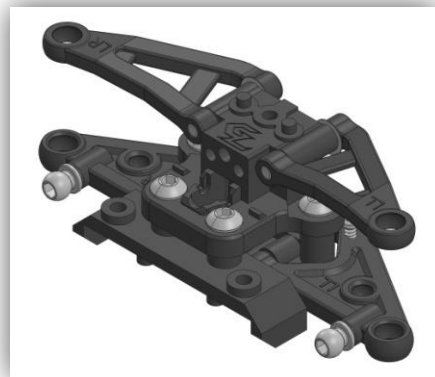
**SM1 x2**  
 (2x4x0.1)





H15 x1



M2x4 KB x2



M2x4 KM x1



M1x2.5 PM x4

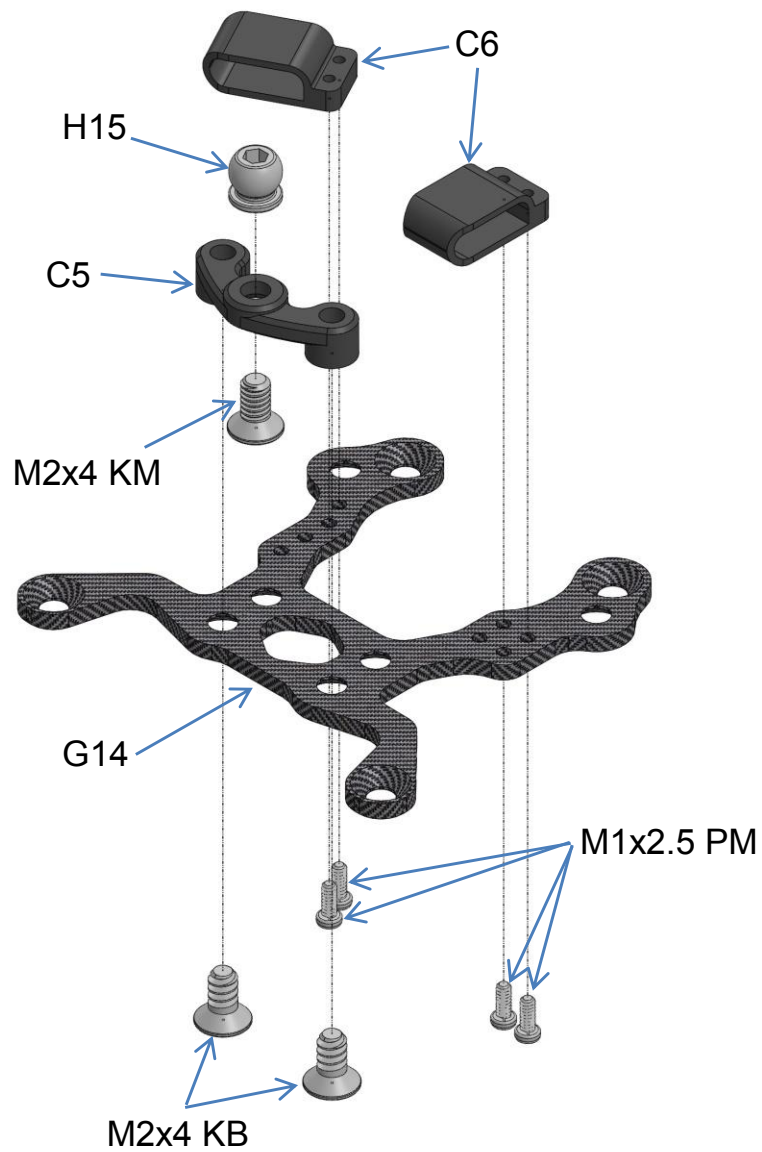



257014 x1



H11 x1  
(Ø1.5x6mm  
Threaded Rod)

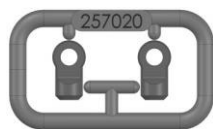
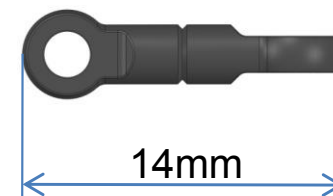
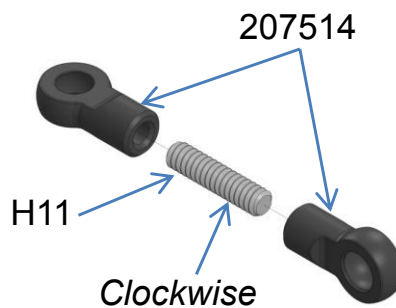

257020 x1



307520 x1



H9 x2

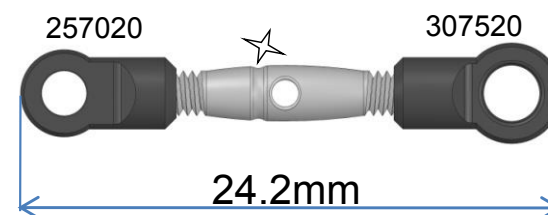
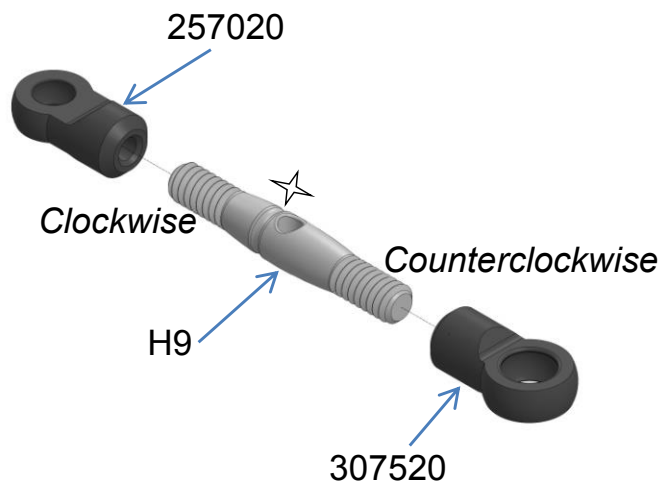



M2x4 KB x2



M2x4 x2  
(Cup Head)



M1.5x3.5 PM x1



H12 x1  
(BS-2502)

Options: GL-0820-TG  
GL titanium gear servo



M2x4 KB

G13

A1

GT-S-035

M2x4  
(Cup Head)

A3

H12

M1.5x3.5 PM

M2x4  
(Cup Head)

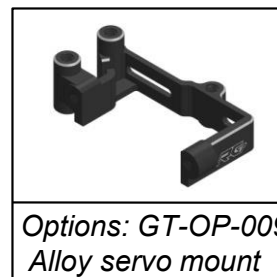

Options: GT-OP-009  
Alloy servo mount



M2x3 PM x2



M2x4 PB x2



H15 x2  
(BS-3520)

M2x3 PM

G2

G4

M2x4 PB

H15

B3



G1

M2x4 PB

H15

M2x3 PM

G3

B3





M2x4 KB x6



M2x3 KM x1



M2x4 KM x1

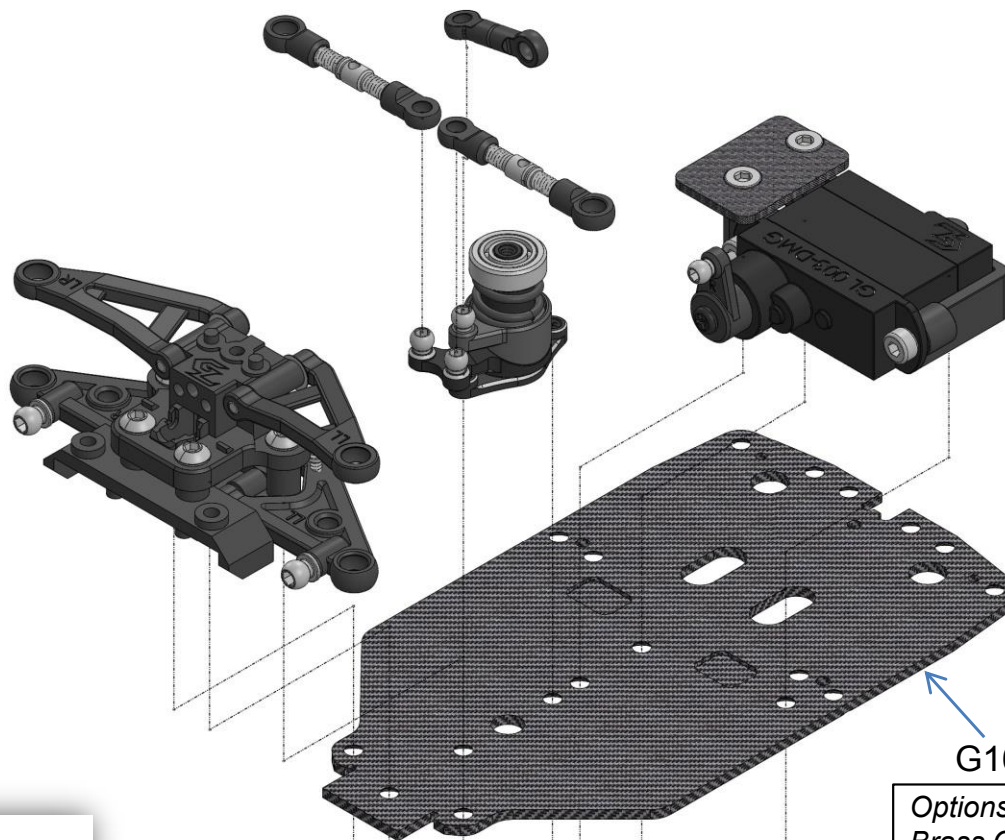

G16

Options: GT-OP-006  
Brass Chassis



M2x3 KM

M2x4 KM

M2x4 KB

M2x4 KB

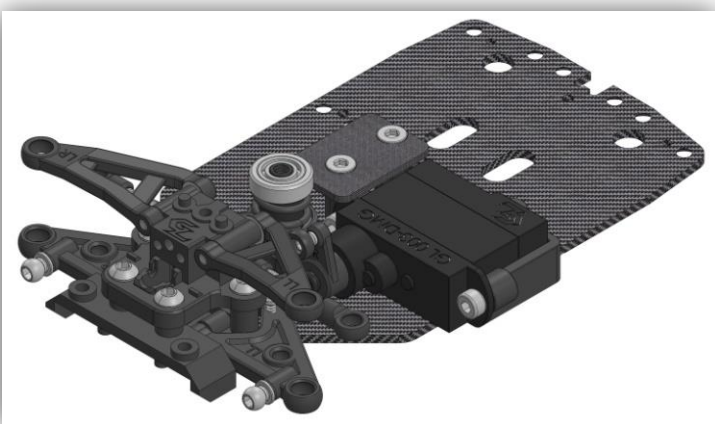



M2x4 KB x8



M2x6 KB x2

Options: GT-OP-002-W  
Front Anti Roll Bar set

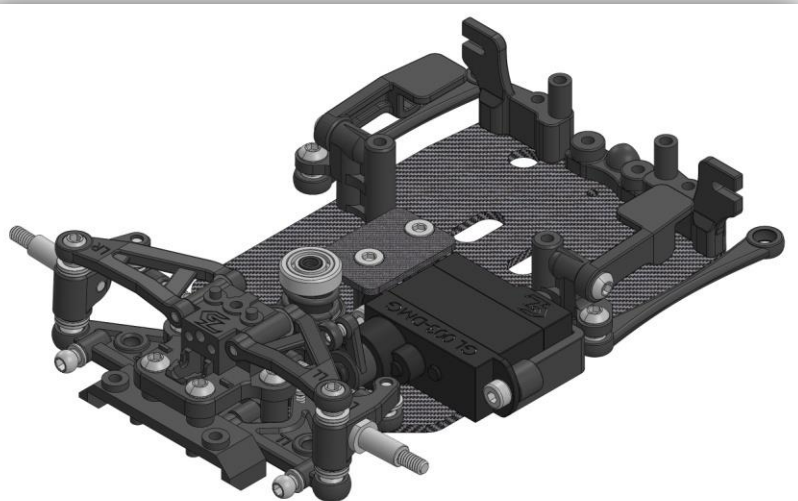
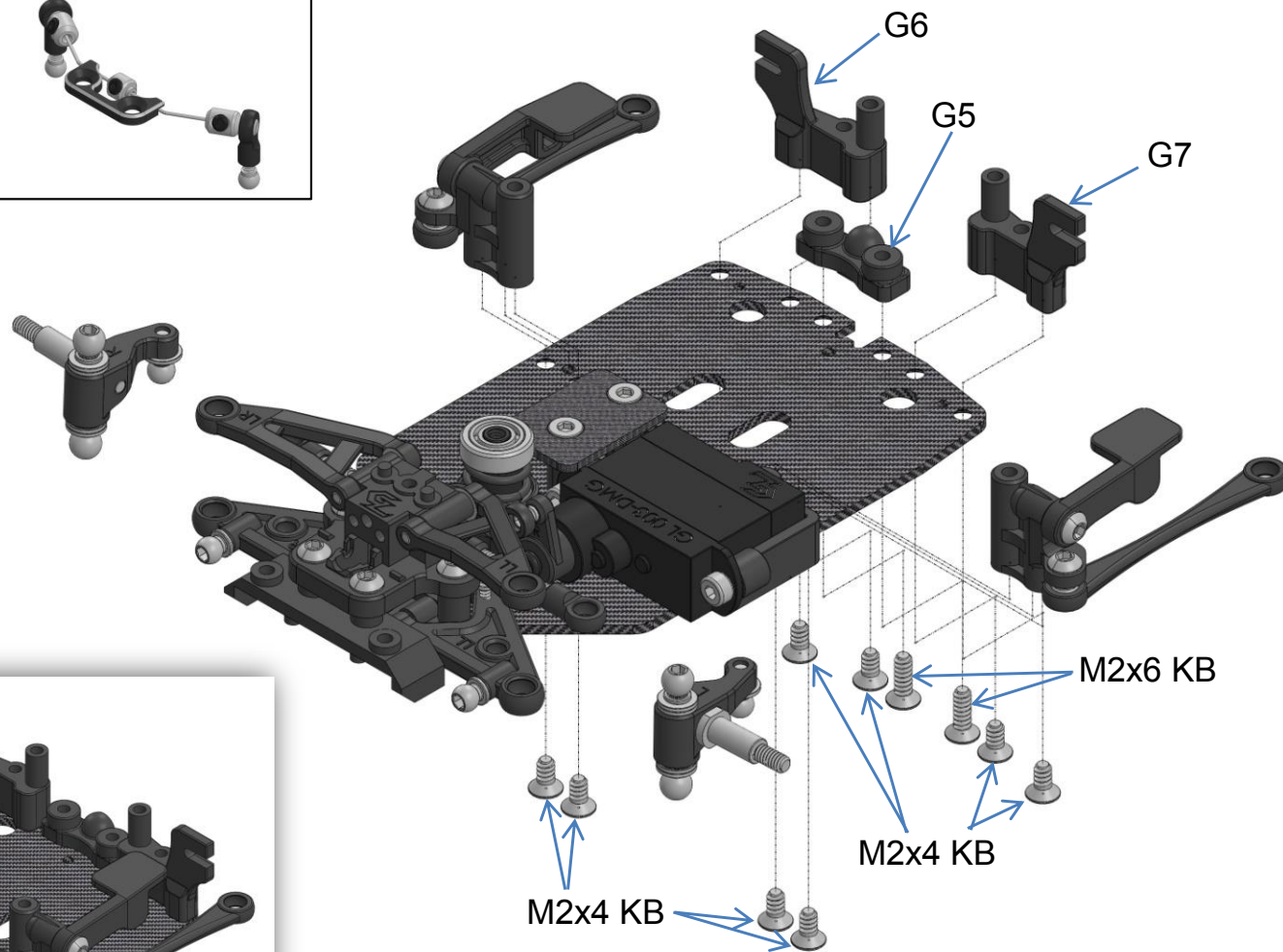

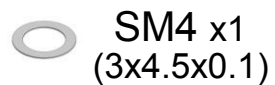

Options: GT-OP-013  
Transponder Case Pro



Only fit for  
Mini Z Nano  
Transponder  
Unit GP0005M  
sale separated.

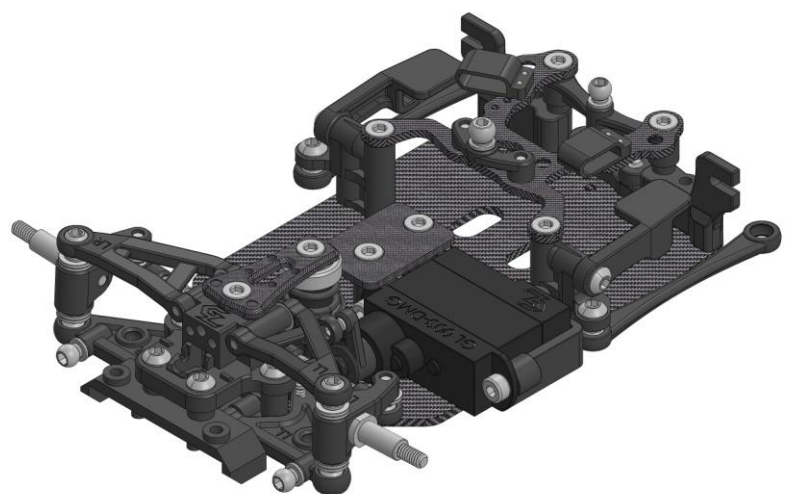
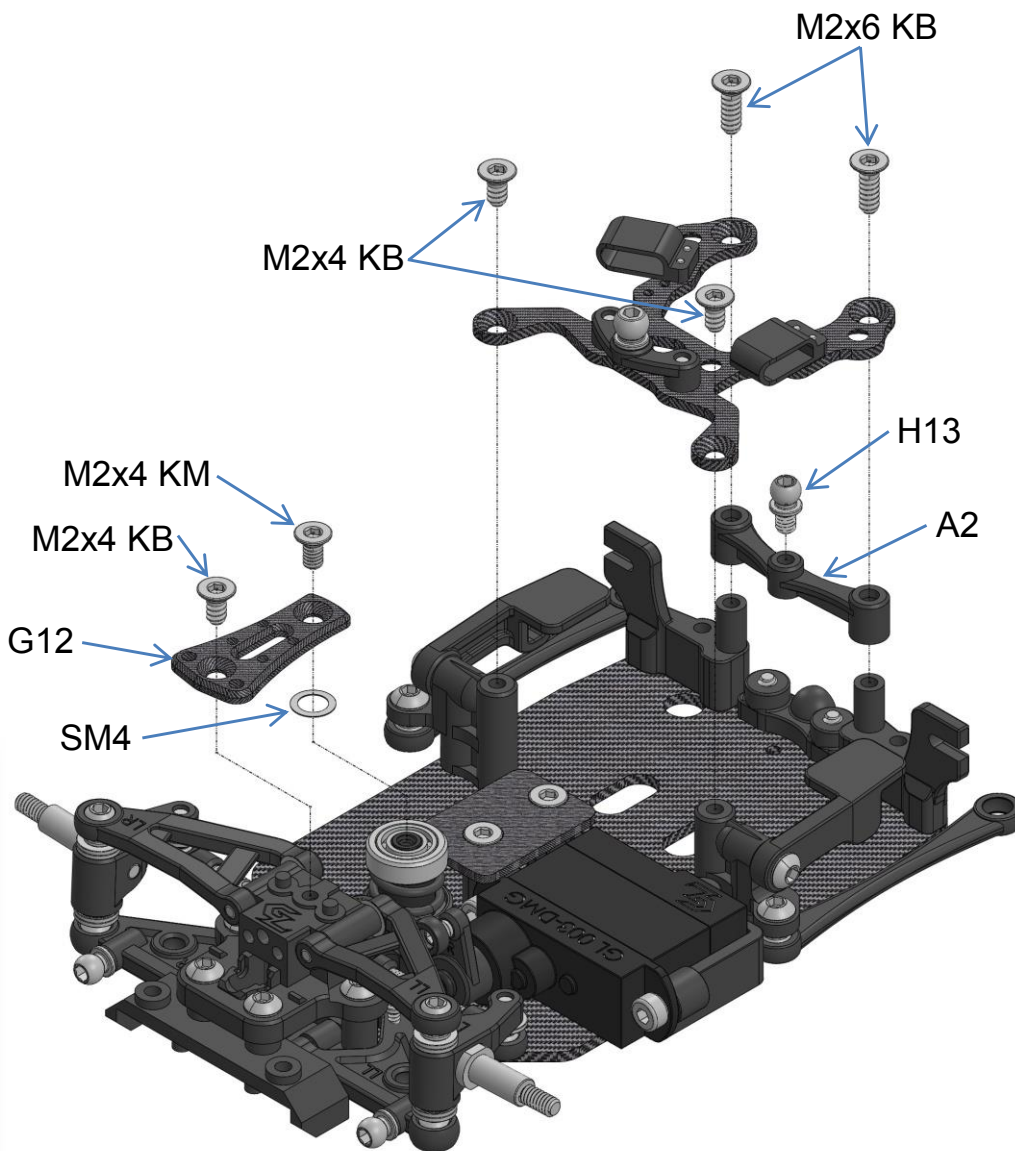

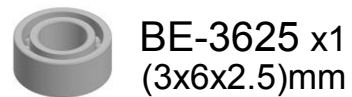

BE-3625 x1  
(3x6x2.5)mm

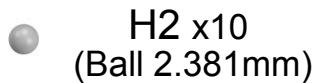

H2 x10  
(Ball 2.381mm)



Spur Gear  
53T x1

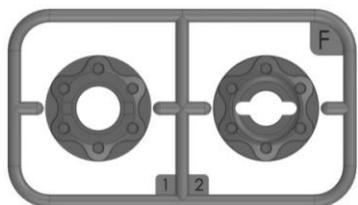

F Pack x1



M1.2x2.5 PM x2



H13 x2

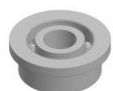

BE-2523 x1  
(2x5x2.3mm with Flanged)

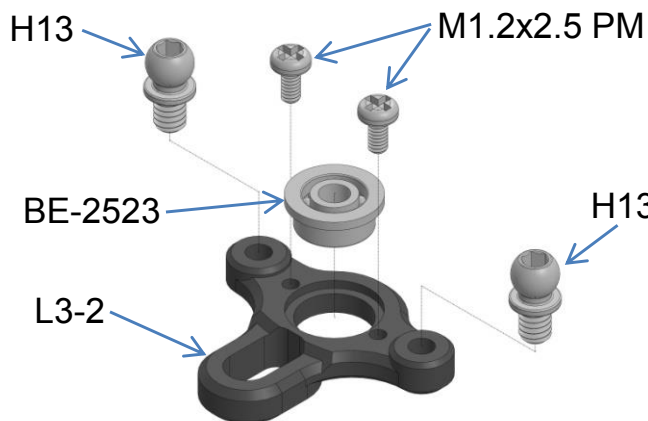
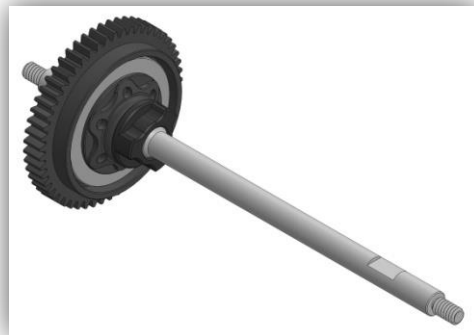
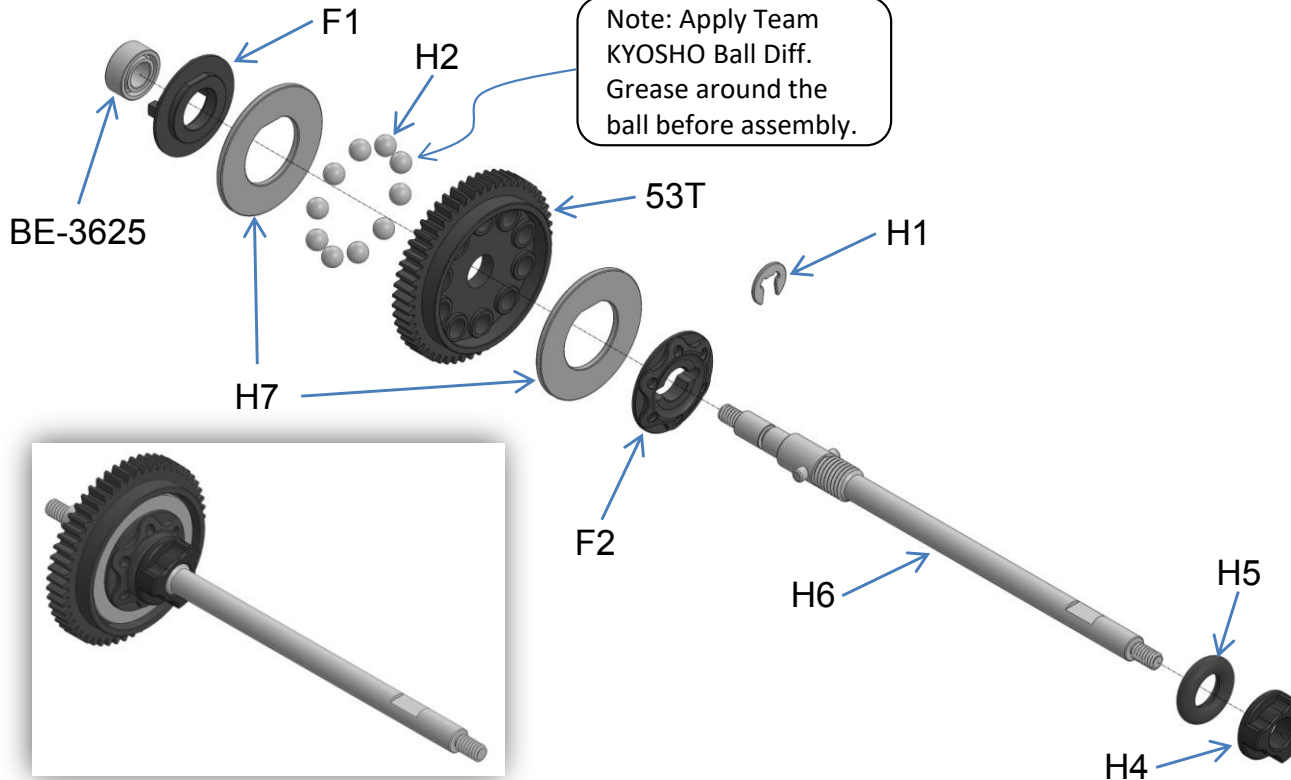



-  M1.2x4 PB x2
-  M1.5x3.5 PM x2
-  M2x3 KM x2
-  M2x4 KM x4
-  M2x4 PM x2
-  H13 x3  
(BS-3025)
-  H15 x2  
(BS-3520)
-  BE-3625 x2  
(3x6x2.5)mm
-  SM2 x1  
(2x4x0.2)

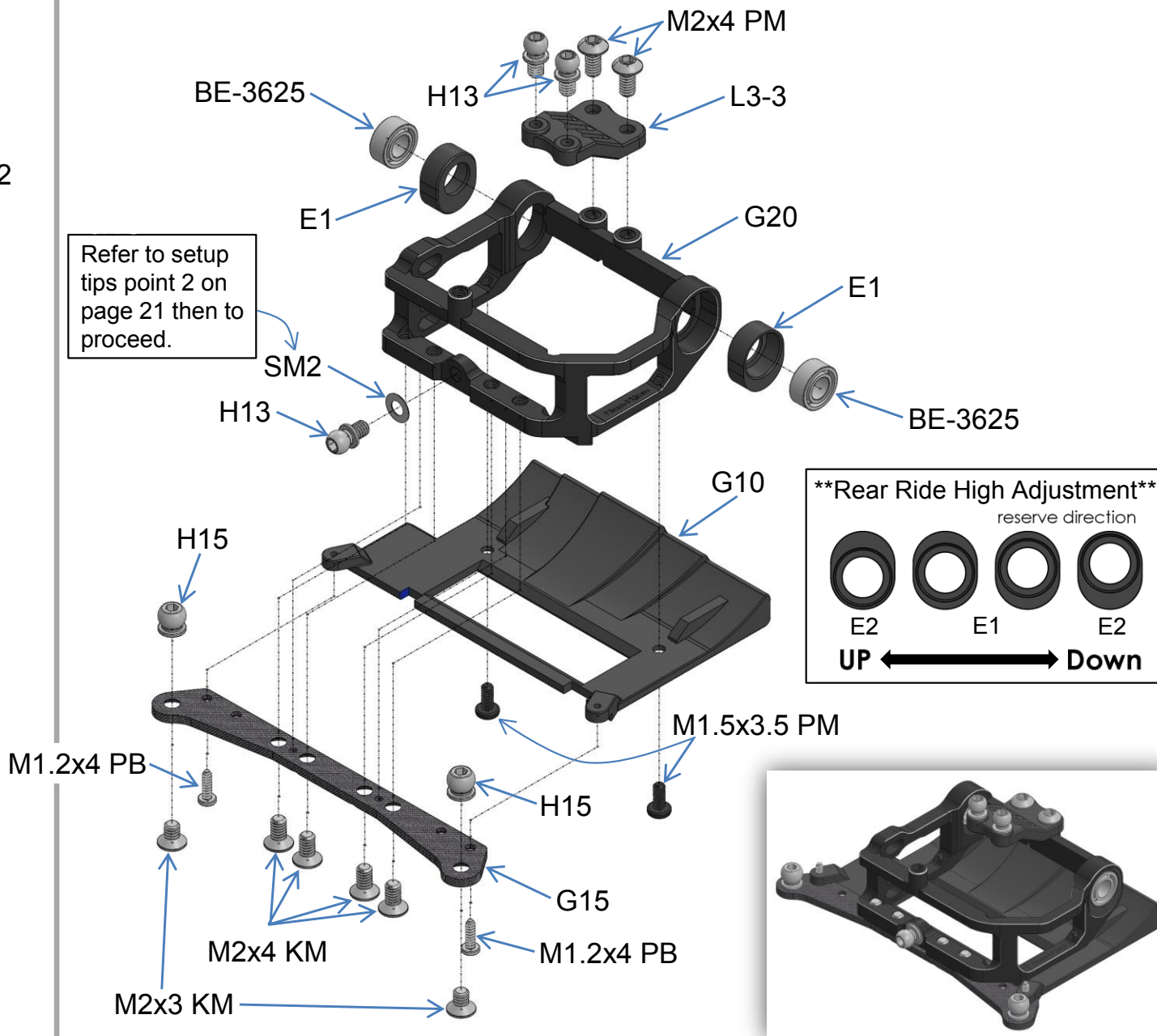

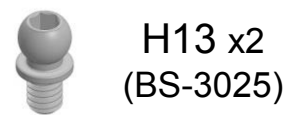
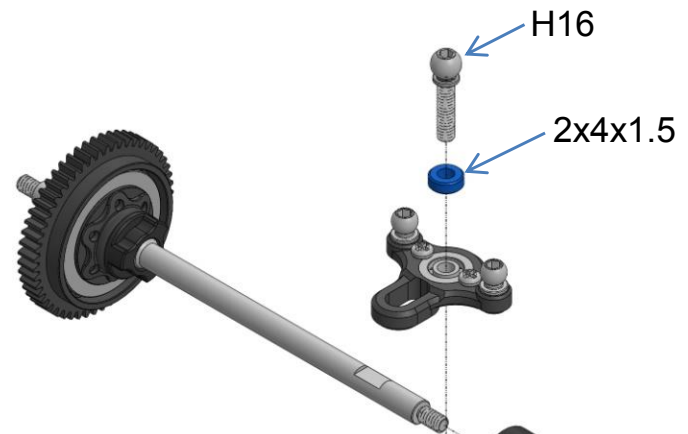
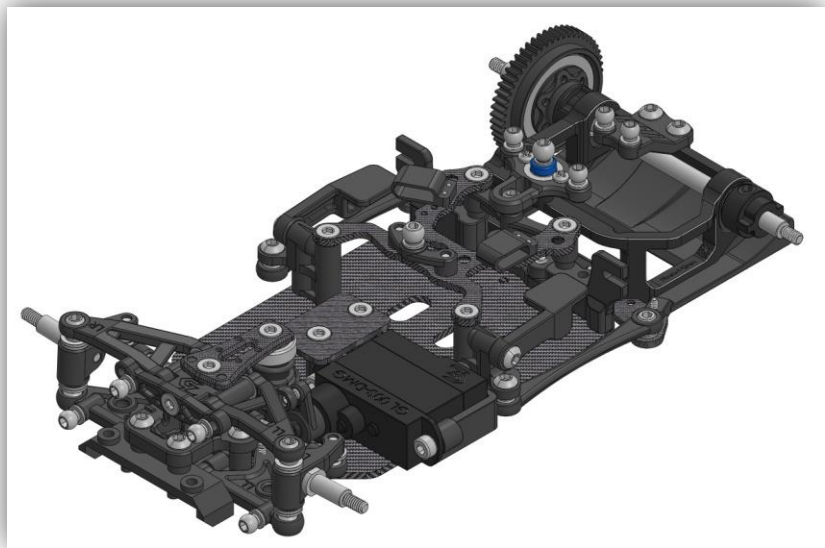

H13 x2  
(BS-3025)



H16 x1  
(BS-3580)



2x4x1.5 x1



M3x3 Grub x1



M2x6 KB x1

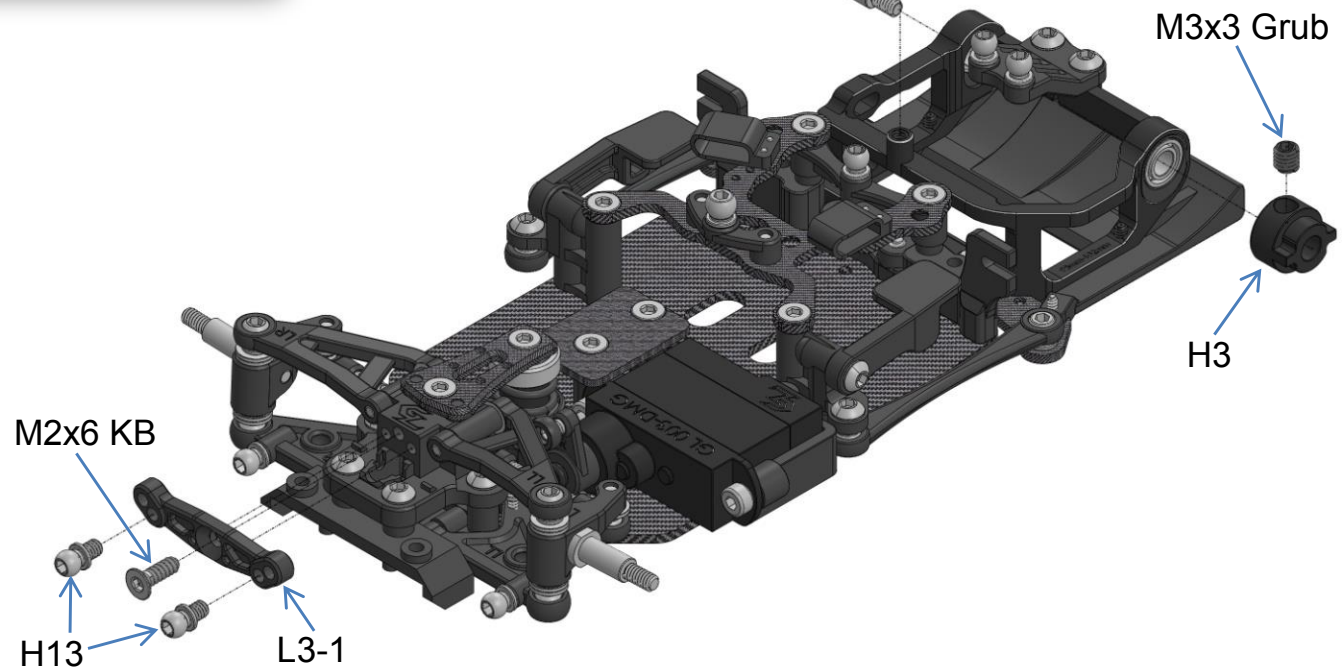

Options: GT-OP-007  
T6 Alum. Front Shock Tower



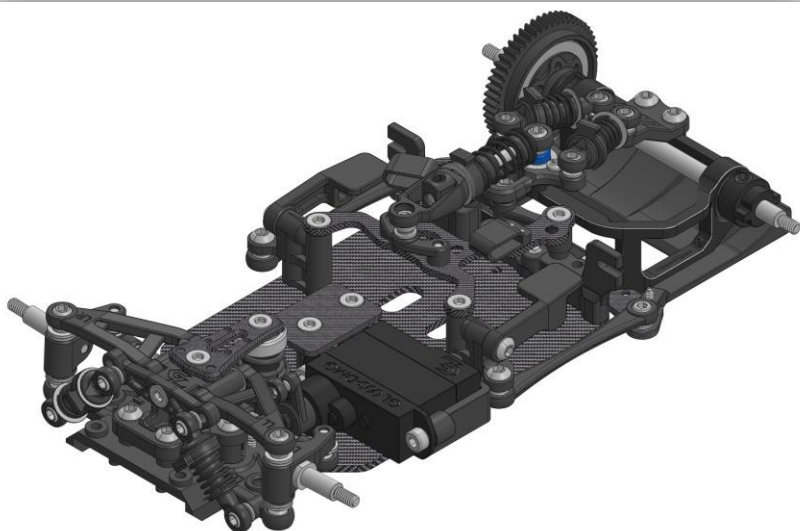

Options: GT-OP003-C  
Spring Set -CS

Hard ← → Soft

Options: GT-OP-003 Adjustable central shock	
Options: GT-OP-004 Adjustable screw Shock	

 SP-1 x4 (Ø5.3x6.5)mm	 SP-2 x1 (Ø6x11)mm	
 SM6 x8 (4.2x6.4x0.2)	 SM7 x4 (5x7x0.2)	 M2.5x2 Grub x1
 H10 x1	 357520 x1	

Note: Apply Team KYOSHO #15000 Ball Diff. Grease (not included) around **ALL** damper pins before assembly.

Options: GT-OP-001  
Spring Set -F/R

Hard ← → Soft

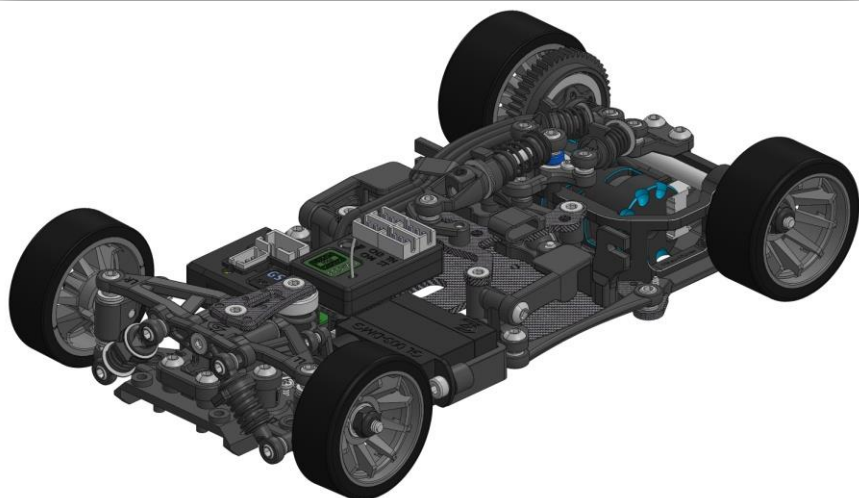

Options: *GL-SD-ESC-010T*  
Brushless Sensored ESC



Brushless Motor is **NOT INCLUDED**  
Recommended 3500KV for Stock  
And 4500KV for Modified  
Available at GL Online Shop

GLR-GT Gear Ratios				
	51	52	53	54
9	5.67	5.78	5.89	6.00
10	5.67	5.20	5.30	5.40
11	4.64	4.73	4.82	4.91
12	4.25	4.33	4.42	4.50
13	3.92	4.00	4.08	4.15
14	3.64	3.71	3.79	3.86

BE-3625 x5  
(3x6x2.5)mm

M2x4 Cup Head x2

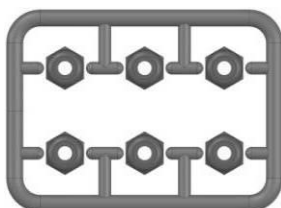

Lock Nut x1

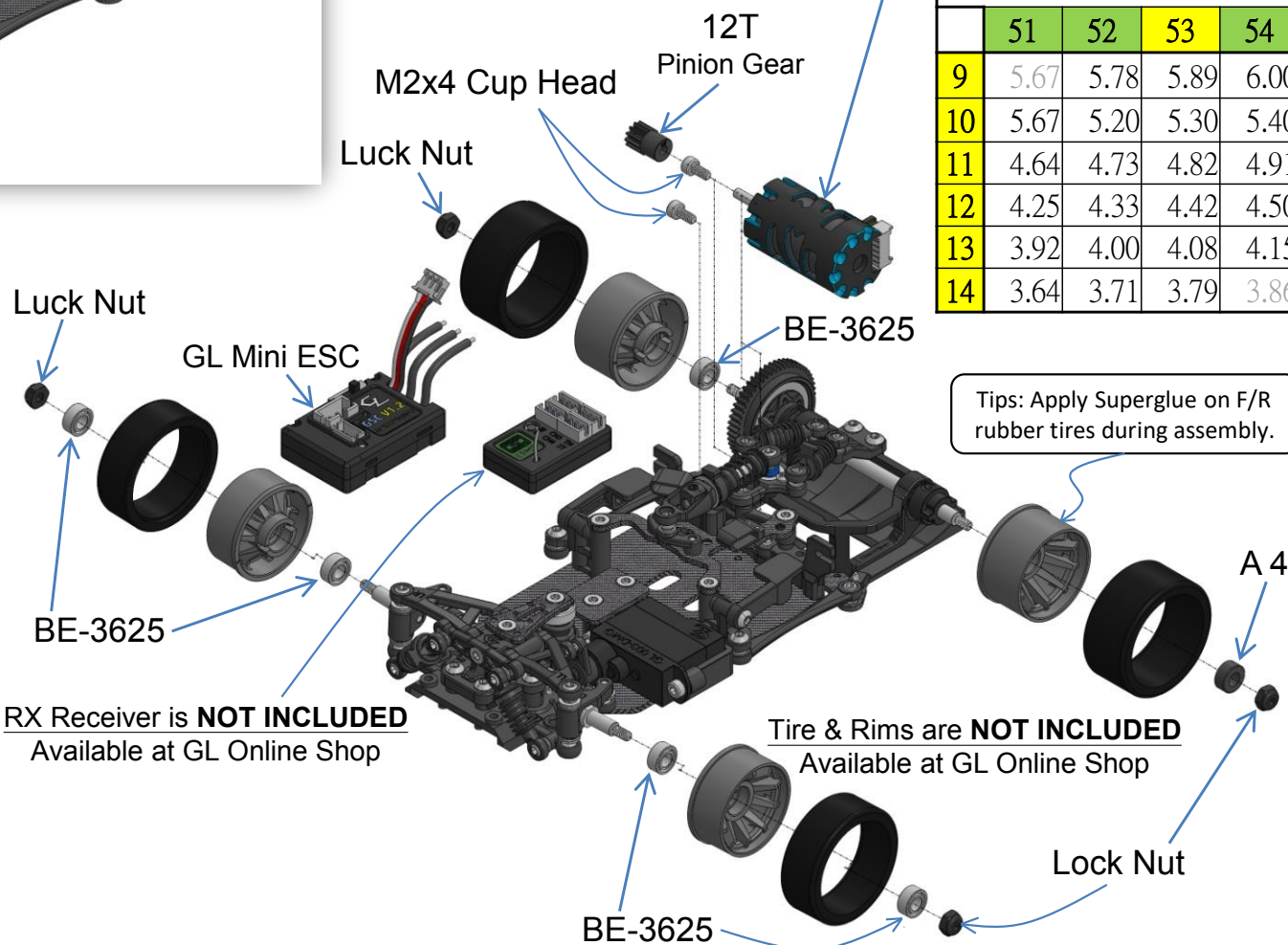

RX Receiver is **NOT INCLUDED**  
Available at GL Online Shop

Tire & Rims are **NOT INCLUDED**  
Available at GL Online Shop

Tips: Apply Superglue on F/R rubber tires during assembly.

# Basic setup/assembly tips before 1<sup>st</sup> run on RCP Track

- 1, Checking all the ball joints and movement parts are moving freely. Especially motor and sensor wire are installed.
- 2, Check that the Rear-Subframe (P-17) can move very freely after assembly, check shim amount for best free movement. Please refer to the link "[http://gl-racing.com/GLR/v1/guide/#rear\\_subframe](http://gl-racing.com/GLR/v1/guide/#rear_subframe)" for more setup and assembly details.
- 3, Applying suitable grease on ball differential (P-16) and Shocks (P-19) which is as thinner as possible and just wrap around the pin is enough. Don't put too much for being maintain frequency.
- 4, Tire around the Rims (P-20) must be fixed with Superglue (Aron Alpha).
- 5, Set the front lower arms both left and right in horizontal. See below Pic 5.1
  - Use cross type screw driver to adjust the screw which is located in backward of the front lower arm. See page 9. **NO DOWN STOP IS REQUIRED IN FIRST SETUP.** Applying down stop may cause steering sensitive which depends on the traction for the RCP track.

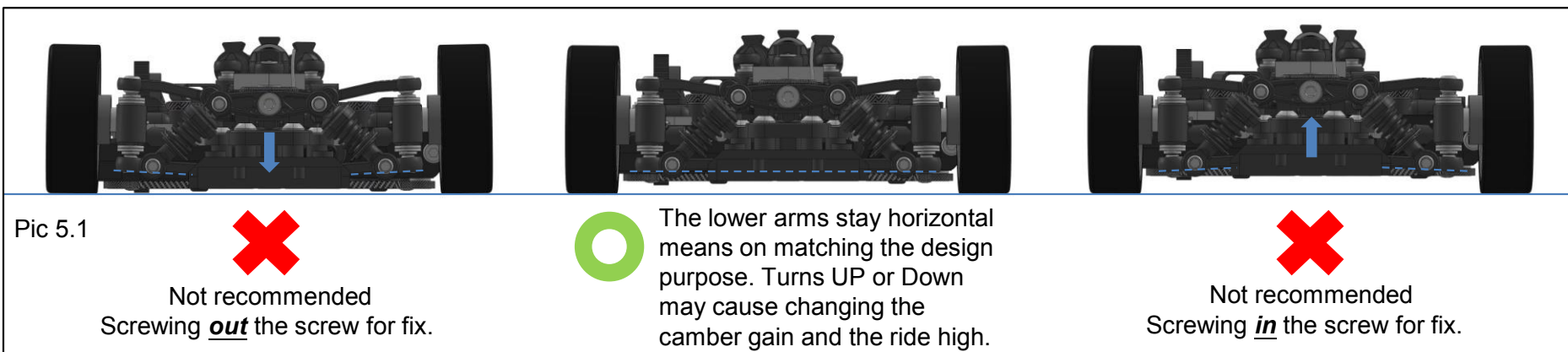

Pic 5.1

Not recommended  
Screwing **out** the screw for fix.

The lower arms stay horizontal means on matching the design purpose. Turns UP or Down may cause changing the camber gain and the ride high.

Not recommended  
Screwing **in** the screw for fix.

- 6, Check the chassis left / right balance. Install wheels in same diameter and place on flat floor. Lift the front up to see left and right wheels apart from the floor, you will see 2 situation below.

6.1 Both side of the wheels are apart the floor at the same time. In this case, congratulations!!! This is the main target that we need to get it. Otherwise, follow the instruction on 6.2.

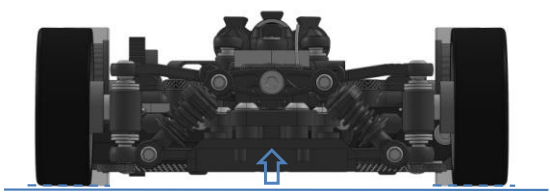

Lift it up

6.2 One of the wheel apart the floor first. For example, if the **left** wheel apart first, adjust the **right** side damper (above the motor) in adding the shim (SM6) until both wheels apart the floor like 6.1. If the right wheel rise up first, do the same on other side.

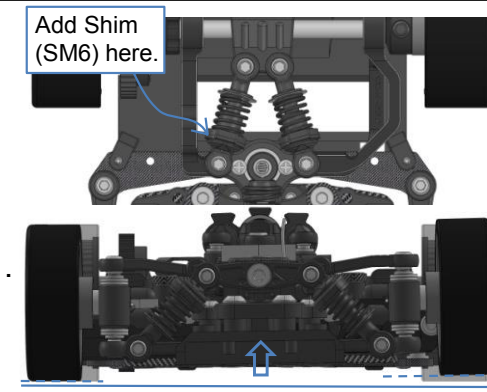

Add Shim (SM6) here.

Lift it up

# Basic setup/assembly tips before 1<sup>st</sup> run on RCP Track

Tips: If the car is new or just re-built, suggest to do point 6 first then to plug sensor and soldering motor wire. It will effect the result if the length of all wires are not suitable. It means that if you did nothing wrong, you will have the same result after all wire installed.

- 7, Keeping the spring preload on **SIDE DAMPER** even if you change the options **GT-OP- 004 Adjust Screw Shock**. The spring should be keep in touch of both end during extend and depress in valid of travelling. This issue may help the chassis running stable. Another change the tension of the side damper, go back to check the point 6 to ensure the chassis balance.
- 8, Check the chassis Front and Rear are staying straight. Detach the C3 first (page 19). See pic below 8.1.

Pic 8.1

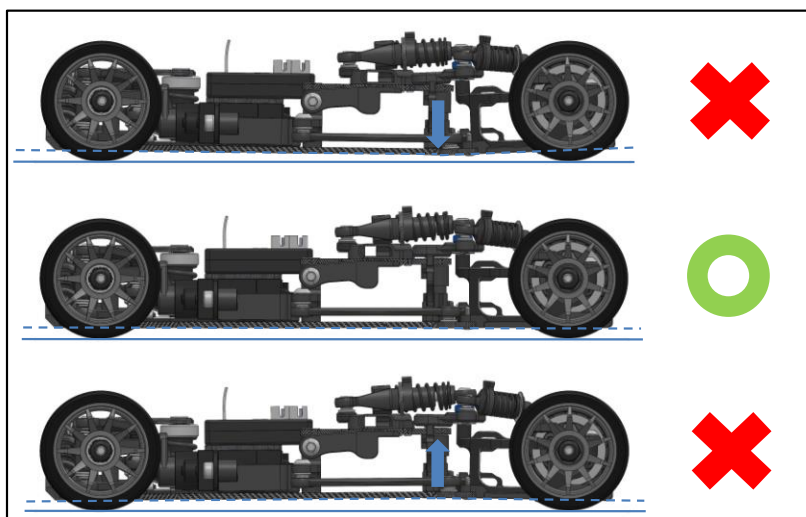

Waist Down

⇐ If the situation is on the left, add the SM7 (see page 19) until the chassis Front and Rear going straight.

⇐ If the situation is on the left, congratulations!!! Go ahead for the race.

Waist up

⇐ If the situation is on the left, remove the SM7 (see page 19) until the chassis Front and Rear down to straight.

- 9, Adjust with NO GAP (no down stop) on Central Shock. See pic 9.1.

Pic 9.1

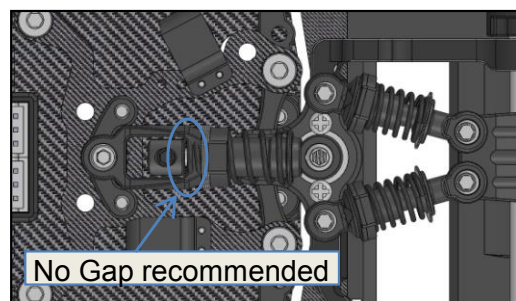

Adjust the C3 (page 19) with NO gap but need to keep the point 8 Front and Rear chassis in straight. This Gap = Down Stop for having unstable in all the time running on the high traction RCP track.

## Basic setup/assembly tips before 1<sup>st</sup> run on RCP Track

10, Adjusting ride high around **2mm** on front (P-8) and rear (P-17) before run. See pic 10.1.

Pic 10.1

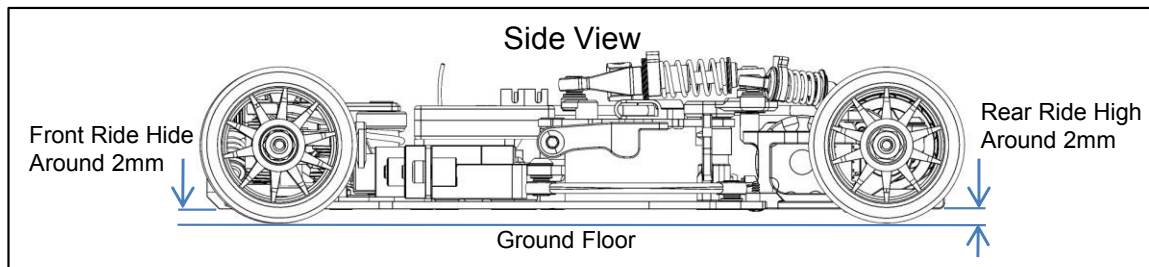

11, Adjust the length of Steering Rods (P-11) in between 24.2mm to 24.5mm. See Pic 11.1. Shorter may cause toe-out (recommended) for stable in cornering and running straight. Adjust it longer may cause less toe-out to toe-in for steering sensitive.

Pic 11.1

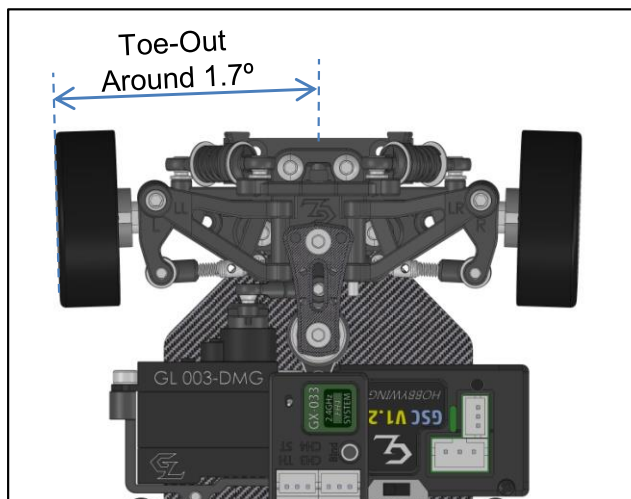

Steering Rod length

24.2mm is around toe-out 1.7° per side

24.5mm is around toe-out 0.2° per side

12, For beginner: Motor 2500KV, Front Tire GT0001-S19/GT0001-S20, Rear Tire MZR-V1R05/MZR-V1R10.

13, For stock: Motor 3500KV, Front Tire GT0001-S18.5/GT0001-S19. Rear Tire MZR-V1R05/MZR-V1R10.

14, For modified: Motor 4500KV or above, Front Tire GT0001-S18/GT0001-S18.5, Rear Tire MZR-V1R05/MZR-V1R10.

15, After the body shell installed (Auto Scale or Lexan) to the chassis, check all the moving parts and steering turned be freely before run.

# Recommended Basic Options Parts

**GT-OP007**  
GLR-GT T6 Alum. Front Shock Tower - Wide

**GLR-GT Transponder Case PRO**  
GT-OP-013

**GT-OP-003**  
GLR-GT Central Shock - L

**GLR-GT Adjustable Screw Shock**  
GT-OP-004

**GLR-GT Rear Shell Post 98mm-102mm**  
GT-OP-005

**GLR-GT Brass Chassis**  
GT-OP-006

**GLR-GT Anti-Roll Bar - Wide**  
GT-OP-002-W

**GLR-GT Adjustable Screw Shock**  
GT-OP-004

**GL titanium gear servo**  
GL-0820-TG

**GL-SD-ESC-010T**  
Brushless sensed ESC

**GL-CR-20**  
GL Connector

**GT-OP-009**  
GLR-GT T6 Alum. Servo Mount

**GLR-GT T6 Alum. Steering Knuckles**  
GT-OP-008-0  
GT-OP-008-1  
GT-OP-008-2  
GT-OP-008-3

**Carbon Lexan Bumper Set**  
GT-OP-028